



STAIRMASTER® 4000 PT OWNER'S MANUAL



StairMaster®
THE RESULTS YOU WANT™



StairMaster®



Printed in the United States.
© 2001 StairMaster® Health & Fitness Products, Inc.
All rights reserved.

Corporate Headquarters

12421 Willows Road N.E., Suite 100
Kirkland, WA 98034

(800) 635-2936
(425) 823-1825
Fax (425) 823-9490
www.stairmaster.com

P/N 22868-A

© 2001 StairMaster Health & Fitness Products, Inc. StairMaster and FreeClimber are registered trademarks or trademarks of StairMaster Health & Fitness Products, Inc. in the United States and/or other countries. All other trademarks are trademarks of their respective companies. StairMaster is a Rutledge Capital Company



WARRANTY

This is to certify that the StairMaster® 4000 PT® exercise system is warranted by StairMaster Health & Fitness Products, Inc. to be free of all defects in materials and workmanship. This warranty does not apply to any defect caused by negligence, misuse, accident, alteration, improper maintenance, or an “act of God.” This warranty is non-transferable from the original owner.

If, within three years from the date of purchase, any part of the StairMaster 4000 PT exercise system should fail to operate properly (except any accessories), contact our Customer Service Department to report the problem. When calling, please be prepared to provide the customer service representative with the following information:

- Your name, customer number, shipping address, and telephone number
- The model and serial number of the inoperable machine
- The date(s) of purchase for the inoperable machine(s)
- Your billing address

This information will ensure that you are the only one ordering parts under your warranty protection. If warranty replacement parts are shipped to you, you may be required to return the inoperable parts. To facilitate this process, the following policy has been established:

- Please call our Customer Service Department to receive a Return Material Authorization (RMA) prior to shipment.
- StairMaster Health & Fitness Products, Inc. will incur all freight charges for warranty parts ordered for a machine that is less than 45 days old. The parts will be shipped to you via an overnight courier.*
- You are responsible for freight charges on warranty parts for machines that are more than 45 days old. You will not be responsible for the return shipment of the inoperable parts.
- Some inoperable warranty parts must be promptly returned to our Customer Service Department. We will pay the shipping cost for the inoperable warranty parts. Detailed instructions are included with each warranty replacement part.

StairMaster Health & Fitness Products, Inc. neither makes, assumes, nor authorizes any representative or other person to make or assume for us, any other warranty whatsoever, whether expressed or implied, in connection with the sale, service, or shipment of our products. We reserve the right to make changes and improvements in our products without incurring any obligation to similarly alter products previously purchased. In order to maintain your product warranty and to ensure the safe and efficient operation of your machine, only authorized replacement parts can be used. This warranty is void if parts other than those provided by StairMaster Health & Fitness Products, Inc. are used.

* Note: Aerosol products cannot be transported via air.

Regular use of the StairMaster® 4000 PT® exercise system is a safe and effective way to develop aerobic fitness while conditioning the major muscles of the lower body. To get the best results, and to keep your machine in peak operating condition, you should carefully read and follow the guidelines presented in this manual.

WHAT IS IN THIS MANUAL?

The first part of this manual includes sections on safety, installation, operating instructions, and preventive maintenance. The second part contains detailed information on problem troubleshooting and repair procedures. An Appendix at the end of the manual provides additional information for the owner.

Throughout this manual, console keypad keystrokes are enclosed in []. The names of the keys and special console operational modes are shown in capital letters. For example, your machine is ready to use when the console displays "SELECT WORKOUT." Press [MANUAL] to start the MANUAL exercise program.

WHAT IS THE STAIRMASTER 4000 PT EXERCISE SYSTEM?

The StairMaster 4000 PT exercise system is a vertical climbing machine with an independent step action. The independent step action, combined with the patented pedal geometry featured on all StairMaster steppers, provides an aerobic workout equivalent to uphill running or climbing stairs, but without the high-impact pounding to the joints and muscles.

CONTENTS

SAFFETY GUIDELINES	1
INTRODUCTION	3
INSTALLATION INSTRUCTIONS.....	4
BASIC OPERATING INSTRUCTIONS	6
General Guidelines for Safe Operation	6
Your First Workout	7
Begin Exercising	7
Rest Periods	8
Cool Down	8
HEART RATE MONITORING	9
Heart Rate Input	9
Locked/Non-locked Option	9
Error Messages	10
TELEMETRY HEART RATE	11
Using the Transmitter Belt	11
Maintaining the Transmitter Belt	12
4000 PT® CONSOLE	13
Display Window	13
Numeric Keypad	14
Entertainment Keypad	14
Intensity Level Keys	14
Stop Key	14
Workout Statistics	15
Exercise Program Keypad	16
The Quick Start Program	16
The Manual Program	16
The Fat Burner Program	17
The Aerobic Training Program	17
The Speed Intervals Program	17
The Constant Heart Rate Program	18
The Fitness Test Programs	19
Understanding Submaximal Exercise Testing	19
Pretest Screening	21

CONTENTS

The StairMaster® Submaximal Fit Test	21
The Firefighter's Stair Climb Tests	24
Turning on the C.P.A.T. Test	25
Turning on the NYCFD Test	25
Console Codes	26
Custom Codes	26
Quick Scan Programming	27
Machine Status Codes	28
Quick Scan Programming	29
Configuration Code	29
MAINTENANCE INSTRUCTIONS	30
Helpful Hints	30
Tool List	30
Maintenance Records	30
Initial Service	31
Preventive Maintenance	31
Cleaning	31
Inspecting	31
Lubrication	32
TROUBLESHOOTING	35
General Troubleshooting Guidelines	35
Electrical Troubleshooting	35
Alternator Test	36
Diode Test	37
Resistor Test	37
CONSOLE DIAGNOSTIC TESTS	38
Display Test	38
Keypad Test	38
Serial Port Test	39
Alternator Test	39
Tach Test	40
Error Reporting	40
Telemetry Heart Rate Test	41



CONTENTS

MECHANICAL TROUBLESHOOTING 42

PARTS REMOVAL AND REPLACEMENT 44

Alternator 44
Alternator Belt 44
Console 45
Covers 45
Drive Chain 46
Drive Hub Assembly 47
Handgrips 48
Handlebar 48
Leveling Arm 49
Pedal 49
Pedal Arm 50
Pedal Arm Return Spring 51
Spring Pulley 51
Step Chain 52
Step Chain Retainer 53
Transmission 53

GROUNDING INSTRUCTIONS 54

FCC COMPLIANCE 55

APPENDICES

Canadian Doc Class B Compliance 55
Important Phone Numbers 56

LIST OF TABLES

Table 1. Dimensions and Specifications for the
StairMaster® 4000 PT® Exercise Systems 3
Table 2. Fitness Rating Norms (VO_{2max}) 24
Table 3. Recommended Preventive Maintenance Schedule 34

LIST OF ILLUSTRATIONS

Figure 1: Level Adjusting End Caps	6
Figure 2: Transmitter Belt	16
Figure 3: 4000 PT® Console	18
Figure 4: StairMaster Fitness Protocol	28
Figure 5: Grounding System	54
Figure 6: Final Assembly - Left Side	57
Figure 7: Final Assembly - Right Side	58
Figure 8: Belt Tension	59
Figure 9: Drive Hub Assembly	60
Figure 10: Drive Chain Tensioning	61
Figure 11: Left Pedal Arm Assembly	62
Figure 12: Transmission	63

WHEN USING ELECTRICAL EQUIPMENT, ALWAYS FOLLOW THESE BASIC PRECAUTIONS:

IMPORTANT SAFETY INSTRUCTIONS



This symbol appearing throughout this manual means Attention! Be Alert! Your safety is involved.

The following definitions apply to the words "Danger" and "Warning" found throughout this manual:

DANGER - Used to call attention to IMMEDIATE hazards which, if not avoided, will result in immediate, serious personal injury or loss of life.

WARNING - Used to call attention to POTENTIAL hazards that could result in personal injury or loss of life.

READ ALL INSTRUCTIONS BEFORE USING THE MACHINE.



DANGER To reduce the risk of electrical shock, always unplug the external power supply from the AC wall outlet before cleaning, maintaining, or repairing.



WARNING To reduce the risk of burns, electric shock, or injury to persons:

1. The external power supply should always be unplugged from the AC wall outlet before removing or installing parts. Never make adjustments or repairs while an exercise program is in progress.
2. Close supervision is necessary whenever the machine is used by or near children, invalids, or disabled persons.
3. Keep your hands away from all moving parts and keep your feet on the pedals while exercising. Do not operate the machine with the side covers removed.



SAFETY GUIDELINES

4. Use this machine only for its intended use as described in this Manual. Do not use parts, attachments, or accessories other than those provided by StairMaster® Health & Fitness Products, Inc.
5. Do not use the external power supply if it has a damaged cord or plug, or if it is not working properly, if it has been dropped or damaged, or dropped into water. Contact our Customer Service Department at 1-800-331-3571 to arrange for the return of damaged parts.
6. Connect the external power supply to a properly grounded AC wall outlet; refer to the "Grounding Instructions" section. Keep all cords away from heated surfaces.
7. To disconnect the external power supply, remove the plug from the AC wall outlet.
8. Never drop or insert any object into any opening on the machine.
9. Do not operate where aerosol (spray) products are being used.
10. Always wear insulated gloves when handling batteries.
11. Do not crush, incinerate, or dismantle the battery. The electrolyte contains sulfuric acid which can cause serious damage to eyes and skin. Should this occur, flush profusely with water and seek medical attention.
12. Do not use the machine outdoors.

The safety level given by the design of this equipment can only be maintained when the equipment is regularly examined for damage and wear. Inoperable components shall be replaced immediately or the equipment shall be put out of use until it is repaired. Failure to follow all guidelines may compromise the effectiveness of the exercise experience, expose yourself (and possibly others) to injury, and reduce the longevity of the machine. Follow all training instructions listed in the manual and/or on the machine. Physical injury may result from incorrect or excessive training.

SAVE THESE INSTRUCTIONS

INTRODUCTION

Throughout this manual, all references to the left or right side and to the front or back are made as if you were on the machine, ready to exercise. For example, the external power supply is plugged into the connector on the right side cover. The dimensions and general specifications of the machine are listed in Table 1.

Table 1. Dimensions and Specifications for the StairMaster®
4000 PT® Exercise System

Physical Dimensions:

Length	41 inches (104 cm)
Width	32 inches (81 cm)
Height	58 inches (147 cm)
Weight	130 pounds (59 kg)

Power Supply Specifications:

U.S., Canada, Japan	120 VAC, 50/60 Hz, 2.5 Amp
International	230 VAC, 50/60 Hz, 2.5 Amp

* Optional power supplies, intended for use outside the United States, are available for 220-240 VAC, 50/60 Hz power requirements.

INSTALLATION INSTRUCTIONS

Your machine requires minor assembly before use. Machines shipped outside the United States need to be uncrated before they can be assembled; refer to the "Uncrating Instructions" included with your machine for the details.

1. Remove all shipping material from your machine including the box that is strapped to the pedals.
2. The rubber end caps, one on each leg of the machine (see Figure 1), are designed to compensate for uneven floors. Each face of the caps is a different thickness and is numbered. Twist the caps, as needed, to stabilize the machine. Make sure the machine is level before you use it for the first time.

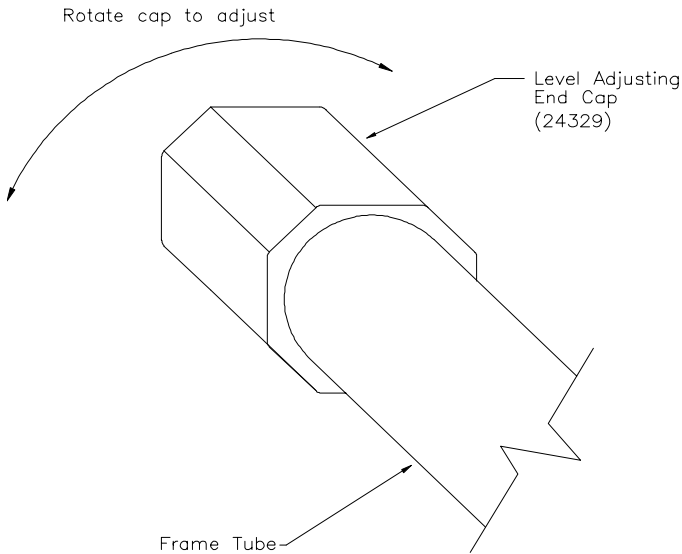

Figure 1: Level Adjusting End Caps

INSTALLATION INSTRUCTIONS

3. Open the box you removed from the pedals and remove the external power supply.
4. Connect the DC **cable** of the power supply to the power connector near the bottom of the right side cover.
5. To reduce the hazard of electrical shock, place the power supply on the floor in a location to avoid exposure to perspiration and near an AC wall outlet. The power supply must rest on a solid surface like a rubber mat or block of wood, do not place the power supply directly on carpet.
6. Check to be sure that the input AC power rating marked on the power supply matches the available power. If it does not, obtain the matching power supply from StairMaster® Health & Fitness Products, Inc. before proceeding any further.



WARNING

TO REDUCE THE RISK OF ELECTRICAL SHOCK AND FIRE AND TO PREVENT SEVERE DAMAGE TO THE MACHINE, USE ONLY THE POWER SUPPLY APPROVED FOR USE WITH THIS EQUIPMENT. IN ADDITION, YOUR MACHINE MUST BE PROPERLY GROUNDED.

7. Connect the AC power cord to the AC wall outlet. Refer to the "Grounding Instructions" section if the AC wall outlet does not accept a three-prong plug.
8. Watch the console. The console should display a software revision code and then show "SELECT WORKOUT." If the console does not, unplug the power supply and then plug it back in. If the console still does not power up correctly, contact our Customer Service Department. Refer to the Appendix for the appropriate phone number.
9. The display "SELECT WORKOUT" tells you the machine is ready to use.

BASIC OPERATING INSTRUCTIONS

GENERAL GUIDELINES FOR SAFE OPERATION



WARNING

THESE GUIDELINES ARE DIRECTED TO YOU, AS THE OWNER OF THE MACHINE.
YOU SHOULD INSIST THAT ALL USERS FOLLOW THE SAME GUIDELINES.
YOU SHOULD MAKE THIS MANUAL AVAILABLE TO ALL USERS.

1. Obtain a complete physical examination from your medical doctor and enlist a health/fitness professional's aid in developing an exercise program suitable for your current health status.
2. When working out for the first time, use the MANUAL exercise program at the lower speeds until you feel comfortable and capable of faster speeds.
3. The speed and duration of your exercise program should always be subject to how you feel. Never permit peer pressure to exceed your personal judgment while exercising.
4. Overweight or severely deconditioned individuals should be particularly cautious when using the machine for the first time. Even though such individuals may not have histories of serious physical problems, they may perceive the exercise to be far less intense than it really is, resulting in the possibility of overexertion or injury.
5. Although all equipment manufactured by StairMaster® Health & Fitness Products, Inc. has been thoroughly inspected by the manufacturing facility prior to shipment, proper installation and regular maintenance are required to ensure safety. Maintenance is the sole responsibility of the owner.

BASIC OPERATING INSTRUCTIONS

YOUR FIRST WORKOUT ON THE STAIRMASTER® FREECLIMBER® EXERCISE SYSTEM

1. Warm up with light calisthenics and easy stretching exercises for at least five minutes before beginning your exercise program.



WARNING

IF AT ANY TIME DURING YOUR WORKOUT YOU FEEL CHEST PAIN, EXPERIENCE SEVERE MUSCULAR DISCOMFORT, FEEL FAINT, OR ARE SHORT OF BREATH, STOP EXERCISING IMMEDIATELY. IF THE CONDITION PERSISTS, YOU SHOULD CONSULT YOUR MEDICAL DOCTOR IMMEDIATELY.

2. Hold onto the handlebars and step up onto the pedals. Stand up straight. The pedals will sink slowly toward the floor.
3. Select the MANUAL exercise program so you can control the pace of your first workout and get used to the exercise motion. Press [MANUAL] and then press [ENTER]. The console will return to the start screen if you do not press [ENTER] within 60 seconds.
4. The console will prompt you to enter your body weight. Enter your weight in pounds (or kilograms if the console is set up for metric units). Correct entry errors by pressing [CLEAR] before you press [ENTER].
5. The console will prompt you to enter your intensity level. Enter your desired intensity level. Correct entry errors by pressing [CLEAR] before you press [ENTER].
6. The console will prompt you to enter the workout time in one minute increments between 5 and 99 minutes. Press [1], [0], [ENTER] to exercise for ten minutes. If you do not start exercising within 60 seconds, the console will return to the start screen.

Begin Exercising

7. Take deep, comfortable steps. Do not let the pedals touch the floor or contact the upper stop. When you begin to exercise, the MANUAL



BASIC OPERATING INSTRUCTIONS

program starts at level three.

8. As you become comfortable with exercise motion, press [LEVEL: ^] and [LEVEL: v] to adjust your climbing speed.
9. Relax and stand up straight while exercising. Use the handlebars for balance (see Figure 5).
10. Select an intensity level that allows you to stay in the middle of the pedal range of motion. Faster is not always better. Exercise at a level that is consistent with your fitness level.

Rest Periods

11. You can stop and rest as many times as necessary for up to one minute for each rest period during all programs. To stop, either press [STOP] or step off the machine. The console returns to the start screen if you rest longer than the allotted rest period. Follow the onscreen prompt to continue your work out after a rest period.

Cool Down

12. When you are finished with your workout, the machine will slow down and the message "GOAL ATTAINED" will be displayed. You can cool down on the machine by continuing to step. The console timer will continue to count up from the selected time to the maximum time, and the intensity level will default to level 3. For example, if the time limit was set for 30 minutes and you worked out for 25 minutes, the cool down period would last for 5 minutes, or until you stepped off the machine. If no time limit is set, the console will count up to 99, return to 0, and start counting up again. Press [STOP] to end the cool down.
13. You can also cool down by getting off the machine walking or stretching for at least five minutes. Lift one foot slowly until the pedal arm contacts the upper stop. Place that foot on the floor. Repeat for the other foot. Do not let the pedals slam into the upper stops, since this may cause unnecessary wear and tear.

HEART RATE MONITORING

HEART RATE INPUT

The 4000 PT console uses telemetry (e.g., Polar®) heart rate signal detection. Ensure that your console is set up for telemetry signal detection only. There is a short “lock out” period at the beginning of each workout session during which the console first detects a signal and then validates the signal type. The duration of this shorter, initial “lock out” period differs between telemetry and contact heart rate.

- Telemetry heart rate - after the initial belt signal is detected, the console will enter a validation phase in which four good heart beat signals within four seconds are required before locking on telemetry heart rate signals for the duration of the workout session. During the validation phase the console will not recognize contact heart rate signals.

Locked/Non-locked Option

When the “not locked” option is selected the heart rate source signal is not fixed during the exercise (if the signal is lost either input will be valid). If the “locked” option is selected then the heart rate source signal is locked on the first detected signal during the workout. To set a heart rate signal input, or to turn off the heart rate option all together, perform the following steps:

1. On the console keypad, press [LEVEL: Û], [3], [2]. At this point the screen will display “HR INPUTS.” Press [ENTER] to select this option.
2. There are 4 options to handle heart rate input signals. Only 2 of those options are appropriate for the 7000 PT; “Both HR Off”, and “Telemetry Only.” Press the [SELECT] key to scroll past the other options until you find either “Both HR Off” or “Telemetry Only.” Press the [ENTER] key to select the desired option.

“TELEMETRY ONLY” - locks out contact heart rate signals and will only detect telemetry signals. Set your console to this default.



HEART RATE MONITORING

"BOTH HR OFF" - turns off the ability to detect any signal at all. Used in rare situations where there is excessive interference with the heart rate signals. This option turns off disables the Constant HR program and the Fitness Test program.

Error Messages

Text line messages are only seen in the Constant Heart Rate and Fitness Test programs due to the design of the program that necessitates a valid heart rate signal at all times during the program.

"CHECK HR BELT" - The heart rate signal has been missing for the last 30 seconds in telemetry signal detection.

"HR BELT NEEDED" - No telemetry belt signal been sensed during the initial setup time.

"HR MODE DISABLED" - No heart rate signal is allowed due to the set up option that was chosen. Heart rate monitoring is not possible.

TELEMETRY HEART RATE

TELEMETRY HEART RATE

The StairMaster® 4000 PT features telemetry (Polar®) heart rate monitoring. The system consists of the receiver, located on the stepper, and a transmitter belt (purchased separately) worn across your chest. The monitoring function is activated as soon as you strap on the chest belt and step within range of the receiver in the machine. Two electrodes on the underside of the chest belt sense the heart rate signal and send it to the receiver. The heart symbol on the console pulses to indicate that the console is receiving a valid signal. A microprocessor in the console calculates the heart rate and displays it, in beats per minute, on the console.

Using the Transmitter Belt



WARNING

PACEMAKER USERS SHOULD NOT USE THE POLAR TRANSMITTER BEFORE CONSULTING THEIR DOCTOR.

Before you put the transmitter belt on, wet the two electrode patches (the grooved rectangles on the reverse side of the belt). Secure the transmitter belt as high under the pectoral muscles (chest) as is comfortable. The transmitter belt should fit snugly and comfortably, and allow normal breathing. When the console detects a heart rate signal, heart rate is shown in the display automatically. Your heart rate in beats per minute and a pulsing heart icon are displayed on the console.

After the initial belt signal is detected, the console will enter a validation phase in which four good heart beat signals lasting four seconds each are required before locking on telemetry heart rate signals for the duration of the workout session. During the validation phase the console will not recognize contact heart rate signals. If you do not see a heart rate on the console, try one of the following:

- Move closer to the console.

TELEMETRY HEART RATE

- Tighten the elastic part of the chest belt.
- Adjust the belt higher or lower on your chest.
- Remoisten the electrodes.
- Test your chest strap with a machine that you know is working, or with a heart rate watch that you know is working.
- If possible, replace or exchange your console with a console (from the same type of machine) that you know is working and retest the machine.
- Visually check that the heart rate receiver is positioned correctly in the neck cover. The heart rate receiver jack should point down. Ensure that the heart rate receiver is connected to the console, and that the connection is not loose. If possible, swap the heart rate receiver with one from another machine.

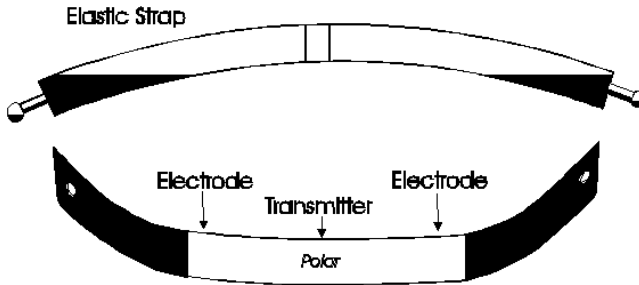

Figure 2: Transmitter Belt

Maintaining the Transmitter Belt

Clean the chest belt regularly with mild soap and water, then dry thoroughly - residual sweat and moisture keep the transmitter active and drain the battery in the transmitter. Do not use abrasives or chemicals such as steel wool or alcohol for cleaning, as they can damage the electrodes permanently. You can order replacement belts from StairMaster, Polar Electro, Inc., or your local fitness store:

StairMaster	800-331-3578	P/N 64000
Polar Electro, Inc.	800-227-1314	

4000 PT CONSOLE

The StairMaster® 4000 PT® systems console is divided into seven sections: the display window, the workout options, the numeric keypad, the entertainment keypad, the workout statistics, the stop key, and the intensity level keys (see Figure 3).

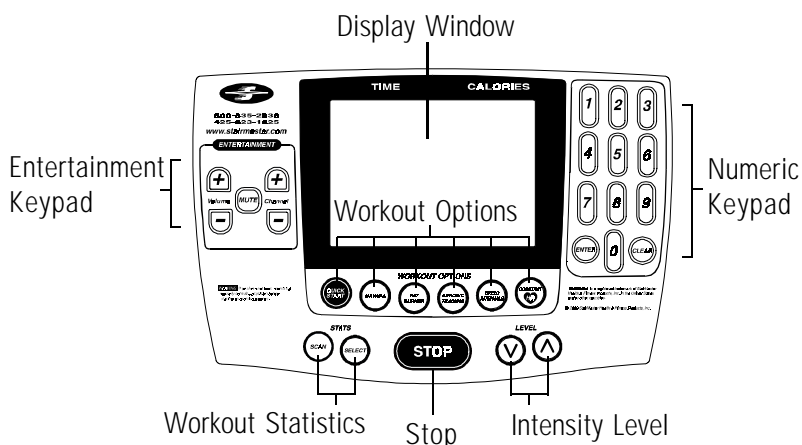

Figure 3: 4000 PT Console

DISPLAY WINDOW



- **Time** - The selected workout time is displayed in the upper left section of the display window. Once the time is entered, the timer will count down, in minutes and seconds, until the workout is finished or stopped. If [0] is entered in the MANUAL or CONSTANT HEART RATE program, the timer will count up.
- **Calories** - The real-time amount of calories burned is continually updated and displayed in the upper right section of the display window.
- **Interval Timer** - The interval timer is displayed below the Time. The interval timer counts down time left within each interval.
- **Heart Rate** - Current heart rate is displayed below the Calories, next to the heart icon.
- **Workout Option Profile** - A profile of the selected exercise program appears in the lower section of the display window during a workout. The taller the column, the higher the intensity (watts) for that interval. The flashing column shows your current interval. The flashing column moves from left to right across the display as you complete each interval.

4000 PT CONSOLE

NUMERIC KEYPAD

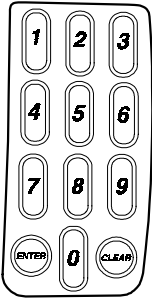

The numeric keypad is located on the right side of the console. Before the exercise program begins, the numbers are used to enter data in response to the console prompts.

- **Enter** - Confirms workout selections and stores the information used by the console to calculate workout statistics.
- **Clear** - Erases information from the console memory if pressed before [ENTER].

ENTERTAINMENT KEYPAD

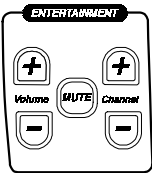

The 4000 PT® comes equipped to facilitate the use of commercial entertainment systems. Using any of these keys will send an output signal through the Communication Specification for Fitness Equipment (C.S.A.F.E.) port to a connected C.S.A.F.E. or compatible system. If a system is not connected, pressing these keys will have no effect.

- **Volume Up/Down** - Increases or decreases the volume level of the audio source.
- **Mute** - Removes the audio sound from the headphones.
- **Channel Up/Down** - Changes the channel of the commercial entertainment system.

INTENSITY LEVEL KEYS



The exercise intensity level may be changed at any time during a workout. Pressing the [v] key decreases the intensity and pressing the [^] key increases the intensity.

STOP KEY



Press the [STOP] key any time you want to pause the exercise program for up to one minute. Press [STOP] a second time, or [1], and The console will return to the "SELECT WORKOUT" Prompt.

WORKOUT STATISTICS

During the exercise program, the Stats keys are used to track workout statistics which are then shown in the display window. Pressing the [SELECT] key turns off the scanning feature and shows the statistic of choice in the display window. Continue to press the [SELECT] key until you reach the desired statistic. Pressing the [SCAN] key will prompt the console to cycle through the following statistics:

- **Distance** - Provides a cumulative total of the equivalent distance (in miles or kilometers), you would have traveled while riding a bicycle outdoors at the same relative intensity.
- **Calories/Hour** - Provides a running total of the number of calories burned during a workout.
- **Rate** - Displays the current steps per minute.
- **Floors** - Displays the equivalent number of floors climbed with an 8-inch step. There are 16 steps per floor, and 48 floors per mile.
- **Level** - Shows the current intensity level between 1 (the easiest) and 20 (the hardest).
- **Watts** - Displays the exercise intensity in watts (746 watts = 1 horsepower).
- **METS** - Gives you the relative energy cost of exercise. MET stands for multiples of the resting metabolic rate. While you are sitting quietly, your body consumes oxygen at the rate of about 3.5 milliliters per kilogram of body mass per minute. When you exercise, your body needs more oxygen in order to function. For example, exercising at 10 METs requires ten times the resting rate of oxygen consumption, or about 35 milliliters per kilogram per minute. During a workout, this key shows the current MET level. During the workout summary, the average MET level is displayed.
- **Target Heart Rate** - Available only during the Constant Heart Rate program. Shows the selected target heart rate.

At the completion of a workout, the statistic averages are calculated based on the accumulation of data during the workout program, and not including the cool down period.

4000 PT CONSOLE

EXERCISE PROGRAM KEYPAD

The exercise keypad is located below the display and to the left of the function keypad. While the console is in the "SELECT WORKOUT" mode, press one of the exercise program keys to preview the desired workout. There are six workout programs with the following standard defaults (pressing [ENTER] without inputting data first will prompt the console to enter these values):

- **Weight** - 175 lbs.
- **Intensity Level** - 3
- **Workout Time** - The default time in the programmed workouts and Quick Start is 20 minutes. The Manual and Constant Heart Rate programs do not have a specified default time. In these programs, the console timer will count up to the maximum time of 99 minutes, and then return to 0.
- **Age** (Constant Heart Rate program only) - 40 years

Once you have selected a program, the prompts are:

- **"ENTER BODY WEIGHT"** - type in your body weight in pounds (or kilograms if your console is set to metric units).
- **"ENTER LEVEL 1 - 20"** - select your intensity level with level 1 being the easiest and level 20 the hardest.
- **"ENTER TIME 5 - 99"** - select the workout duration in one minute increments from 5 to 99. Press 0 in the MANUAL and CONSTANT HEART RATE program to workout for an unspecified amount of time.

The Quick Start Program

Provides an immediate start, without having to enter any user information. This program uses the standard default settings for derivation of calories burned.

The Manual Program

After pressing the [MANUAL] key, enter user and workout information. Begin exercising at the selected level. If desired, adjust the workout manually by using the intensity level arrow keys. The profile in the display window is divided into 15 equal intervals within the workout time. The profile is based

on the selected intensity level, with 2 levels equating to one vertical bar.

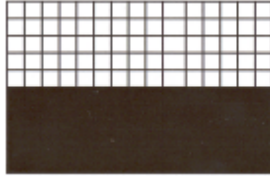

The Fat Burner Program

The Fat Burner program is a 60-interval workout designed for people just starting a weight control program. The relative intensity level is indicated on the profile and any changes in the intensity level will continue for the remainder of the program.



The Aerobic Training Program

The Aerobic Training program is a 60-interval workout designed to increase aerobic capacity. The relative intensity level is indicated on the profile and any changes in the intensity level will not change the look of the remaining profile.



The Speed Intervals Program

The Speed Intervals program is a workout with 8-rest intervals and 7-exercise intervals that alternate speed/intensity level changes. You can change the REST interval speed/level and the EXERCISE interval speed/level independently, using the level keys. For example, if you decrease the intensity level during a rest interval then subsequent rest intervals will be the same. However, the EXERCISE interval remains at the same intensity level you started with. To change the intensity level of the EXERCISE interval, you must change

4000 PT CONSOLE

the intensity level during an EXERCISE interval. The intensity level shown during an EXERCISE interval is indicative of your current speed. However, the current speed during a REST interval is equal to a scaled percentage of the displayed intensity level. Note that the program profile does not change at any time during the workout session.

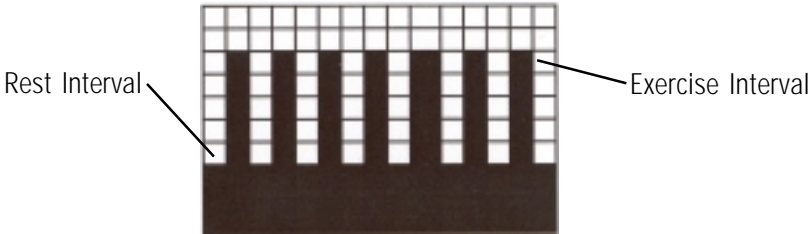

The Constant Heart Rate Program

The Constant Heart Rate program maintains a chosen target heart rate by automatically varying the climbing speed during each workout. The default target heart rate is equal to 70% of your maximum heart rate which is calculated by the following equation: $220 - (\text{Age}) \times .70$. Choose a different target heart rate (between 80 and 180 beats per minute) at any time during the workout by using the numeric keypad to enter the new target heart rate, followed by the [ENTER] key. The following messages may be shown during a workout:

- **“CHECK HR BELT”** - The heart rate signal has been missing for the last 30 seconds in telemetry signal detection.
- **“HR BELT NEEDED”** - No telemetry belt signal has been sensed during the initial setup time.
- **“HOLD HR SENSORS”** - In contact heart rate signal situations this message will come every 30 seconds to prompt the user to hold the sensors.
- **“HR MODE DISABLED”** - No heart rate signal is allowed due to the set up option that was chosen. Heart rate monitoring is not possible.

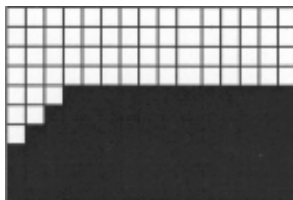

THE FITNESS TEST PROGRAMS

Understanding Submaximal Exercise Testing

Before using the StairMaster® 4000 PT® for submaximal exercise testing, it should be noted that all submaximal fitness tests make several assumptions:

- That a steady-state heart rate is obtained for each exercise workload.
- That a linear relationship exists between heart rate, oxygen uptake and workload.
- That the maximal heart rate for a given age is uniform.
- That the mechanical efficiency of the physical activity performed (i.e., oxygen uptake at a given workload) is the same for everyone.

It should be kept in mind that any one or all of the above mentioned assumptions may not be met during a submaximal exercise test. If for any reason one of the assumptions is not met, then errors in predicting $\text{VO}_{2\text{max}}$ will occur.

Unfortunately, it is often quite difficult to meet all of the requirements for the four listed assumptions. For example, exercising at a given workload for only a few minutes can involve an insufficient amount of time for many individuals to achieve a true steady-state. To ensure that a steady-state has been achieved, the heart rate should be measured after two minutes of exercise at a given workload and again after the third minute of exercise at that workload. These two heart rates should then be compared. If a difference of more than five beats per minute between the two is found, the subject should continue to exercise at one-minute intervals at the same workload until two successive heart rates differ by less than five beats per minute.

It is also important that the submaximal heart rates obtained be between 115 and 150 beats per minute, because it is within this heart rate range that a linear relationship tends to exist between heart rate and oxygen uptake or workload for most adults. When the heart rate is less than 115, many external factors (e.g., talking, laughing, apprehension, etc.) can greatly influence heart rate. Once the heart rate reaches a level between 115 and

4000 PT CONSOLE

150, external factors no longer influence heart rate, and a linear relationship exists. As the heart rate rises above 150, the heart-rate/oxygen uptake relationship becomes curvilinear.

The third assumption involves maximal heart rate. Maximal heart rate is the greatest heart rate that can be measured when an individual is exercising to the point of volitional fatigue (i.e., exhaustion) during a graded exercise test. Several equations have been developed to estimate the average maximal heart rate for humans:

- Maximal heart rate = 220 minus age (low estimate)
- Maximal heart rate = 210 minus [0.5 x age] (high estimate)
- Maximal heart rate = 226 minus age (estimate for older individuals)

Maximal heart rate can, however, vary greatly among different individuals of the same age. One standard deviation is ± 12 bpm, which means that two-thirds of the population varies an average of plus or minus 12 heart beats from the average given by a prediction equation. If an individual's age-predicted maximal heart rate is higher than that person's true maximal heart rate, then his/her estimated $\text{VO}_{2\text{max}}$ will be an overestimation of the correct or actual value.

The final assumption addresses the issue of mechanical efficiency. Oxygen uptake at any given work rate can vary by approximately 15% between different individuals. Therefore, individuals vary in the amount of oxygen they require to perform a certain exercise workload. Some individuals are more efficient at performing a given task than others. As a result, the average oxygen consumption associated with a given workload may vary significantly from one person to another. Thus, $\text{VO}_{2\text{max}}$ predicted by submaximal exercise tests tends to be overestimated for those who are mechanically efficient and underestimated for those who are inefficient.

The point to remember is that submaximal exercise testing, though not as precise as maximal exercise testing, is not without advantages. For example, the results of such testing can provide a fairly accurate reflection of an individual's fitness status without the cost, risk, effort (on the part of the subject) and time involved in max testing. If an individual is given repeated

submaximal exercise tests and that person's heart rate response to a fixed workload is found to decrease over time, it is reasonably safe to conclude that the individual has made improvements in aerobic (cardiorespiratory) fitness, irrespective of the accuracy of the $VO_{2\max}$ prediction.

Pretest Screening

Prior to any exercise test (maximal or submaximal), participants should complete a brief health/medical questionnaire, have their resting blood pressure and heart rate measured, and provide an informed consent form. The Physical Activity Readiness Questionnaire (PAR-Q) is an example of a valid health/medical questionnaire for screening individuals prior to submaximal exercise testing. Canadian health and fitness practitioners have extensively (and quite successfully) used the PAR-Q to determine whether individuals should be given an exercise test. A "yes" answer to any of the following seven questions taken from the PAR-Q would disqualify a participant from taking part in an exercise test until appropriate medical clearance was obtained.

PHYSICAL ACTIVITY READINESS QUESTIONNAIRE (PAR-Q)

1. Has your doctor ever said you have a heart condition and recommended only medically supervised physical activity?
2. Do you have chest pain brought on by physical activity?
3. Have you developed chest pain within the past month?
4. Do you tend to lose consciousness or fall over as a result of dizziness?
5. Do you have a bone or joint problem that could be aggravated by the proposed physical activity?
6. Has a doctor ever recommended medication for your blood pressure or a heart condition?
7. Are you aware, through your own experience or a doctor's advice, of any other physical reason against your exercising without medical supervision?

The StairMaster Submaximal Fit Test

The StairMaster branching protocol is a series of 3-minute stages of continuous exercise at increasing intensity. The first stage is a warmup at approximately 4 METs. The intensity of the remaining stages is based on the heart rate response to the warmup. The test is designed to raise the steady-

4000 PT CONSOLE

state heart rate of the subject to 110 to 150 beats/min for two consecutive stages. It is important to remember that two consecutive heart rate measurements must be obtained in the 110 to 150 beats/min range to predict VO_{2max} . The test typically lasts from 9 to 15 minutes.

In the StairMaster protocol, each work rate is performed for 3 minutes, with heart rates recorded during the final 4 seconds of the 2nd and 3rd minutes of each stage. If the heart rates are within 5 beats/min, then the heart rate during the last minute is plotted against the work rate, and the program advances to the next 3-minute stage. The program continues for 2 to 4 stages until 2 steady state heart rates between 110 to 150 beats/min are obtained in 2 consecutive stages. The line generated from the plotted points is then extended to the age-predicted maximal heart rate. A corresponding maximal work rate and VO_{2max} can then be calculated.

At the end of the 3rd minute of each stage, if the heart rates at the end of the 2nd and 3rd minute are not within 5 beats/min of each other, then that work rate is maintained for an additional minute. At the end of the 4th minute, the heart rate is compared to the heart rate at the end of the 3rd minute. If the heart rates are within 5 beats/min, then the heart rate during the 4th minute is plotted against the work rate. If the heart rate at the end of the 3rd and 4th minute are not within 5 beats/min, then the work rate is maintained for one more additional minute. If the heart rate at the end of the 4th and 5th minutes are within 5 beats/min, then the heart rate at the end of the 5th minute is plotted against the work rate. If the heart rate at the end of the 4th and 5th minutes are not within 5 beats/min, then the test failed.

Once 2 consecutive heart rate measurements are obtained in the 110 to 150 beats/min range, then the test ends successfully and the results are displayed. The estimated maximum aerobic capacity is shown in ml/kg/min and METs. Next, the results are compared to normative values for others of the same age range and gender (see Table 2). Results are stored in the console until the next person starts an exercise program.

Figure 4: StairMaster® Fitness Protocol

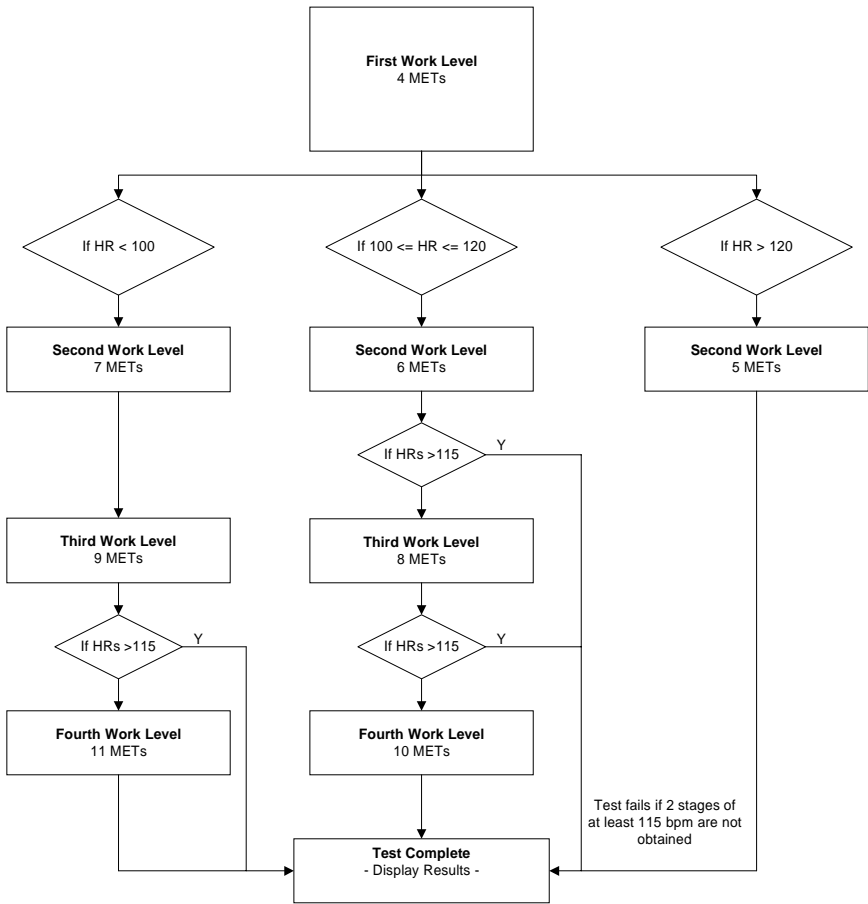

4000 PT CONSOLE

Table 2. Fitness Rating Norms (VO_{2max})

MEN					
Age	High	Good	Average	Fair	Low
20 – 29	>51	51 – 47	47 – 43	42 – 40	<39
30 – 39	>50	50 – 45	45 – 41	41 – 37	<37
40 – 49	>48	48 – 42	42 – 38	38 – 35	<35
50 – 59	>45	45 – 39	38 – 35	35 – 32	<32
60+	>43	42 – 35	35 – 32	32 – 29	<29
WOMEN					
Age	High	Good	Average	Fair	Low
20 – 29	>44	44 – 38	38 – 35	35 – 32	<32
30 – 39	>41	41 – 37	37 – 34	34 – 31	<30
40 – 49	>40	39 – 34	34 – 31	31 – 28	<28
50 – 59	>35	35 – 31	31 – 28	28 – 26	<25
60+	>35	35 – 39	29 – 26	26 – 24	<24

The Firefighter’s Stair Climb Tests

The StairMaster® Stepmill® is routinely used to assess the aerobic fitness levels of fire fighters in full protective gear carrying heavy equipment. The Candidate’s Physical Ability Test (CPAT), approved by the International Association of Fire Fighters (IAFF) and reviewed by the U.S. Justice Department, requires each candidate to step on the Stepmill at a predetermined stepping pace for a specific period of time. There are two fire fighter specific Stair Climb Test programs. The first test is the CPAT Stair Climb Test. The second test is a modified version of the CPAT test that is used by the New York City Fire Department (NYCFD). **Both tests can now be simulated on the StairMaster 4000 PT machines.**

- CPAT Stair Climb Test – (Fit Test #2) The first phase is a warmup interval at intensity of 56 steps/min and lasts 20 seconds. At the end of the first interval the time counter will reset to zero. The second phase continues through nine 20 second

intervals at an intensity of 68 steps/min. The CPAT Stair Climb Test has a total of 10 intervals and lasts for 3 minutes, 20 seconds (including warmup).

Turning on the CPAT Stair Climb Test

1. Press [Û], [9], [1], [ENTER], on the console keypad. Make sure to press in the middle of each key and be aware that the corresponding numbers will not show in the console display.
 2. The console will prompt you to "BEGIN FIT TEST." The test can be stopped at any time by pressing [STOP].
- NYCFD Stair Climb Test – (Fit Test #3) The first phase is a warm-up interval at an intensity of 56 steps/min and lasts 60 seconds, followed by a 60 second rest period (no stepping). At the end of the rest period the time counter will reset to zero. The second phase is at an intensity of 68 steps/min and lasts for 5 minutes, 12 seconds.

Turning on the NYCFD Stair Climb Test

1. Press [Û], [9], [2], [ENTER], on the console keypad. Make sure to press in the middle of each key and be aware that the corresponding numbers will not show in the console display.
2. The console will prompt you to "BEGIN FIT TEST." The test can be stopped at any time by pressing [STOP].

4000 PT CONSOLE

CONSOLE CODES

There are three groups of console codes which are differentiated according to function. The first group of codes are customization codes and are used to set defaults such as units, language, heart rate input type, etc. The second group of codes are machine status codes and are used to track hours and other general usage patterns for maintenance purposes. The third group of codes are diagnostic codes and are used for troubleshooting. The following key actions are valid in each group of console codes:

- Pressing [LEVEL ^], [1st #], [ENTER] displays what group of codes is being accessed.
- Pressing [SELECT] or [LEVEL ^] at that point allows you to view all possible selections. Once in this mode pressing [LEVEL v] backs up through the selections; pressing [ENTER] then selects that item. If another test level is available at this point, the [SELECT] / [ENTER] process is repeated.
- Pressing [^] [1st #, or 2nd #], [ENTER] selects that item directly.
- Pressing [CLEAR] exits any of the special access modes.

Custom Codes

[^][3][0]	change workout time limit between 5 to 99 minutes
[^][3][1]	change units (MPH or KMH)
[^][3][2]	choose type of heart rate input and priority (telemetry or contact)
[^][3][3]	- N/A -
[^][3][4]	choose console language
[^][3][5]	change contrast on console
[^][3][6]	- N/A -
[^][3][7]	- N/A -
[^][3][8]	- N/A -
[^][3][9]	reset to factory defaults

1. Change the workout time by pressing [LEVEL: ^], [3], [0]. The console will display "MAX TIME." Press [ENTER]. The console will then display the current time limit. Use the keypad to enter the desired time, then press [ENTER]. For no time limit, press [0]. The console will display "TIME LIMIT OFF."

2. Change the units to either Metric or USA units by pressing [LEVEL: ^], [3], [1], [ENTER]. The console will display the current units - either "USA UNITS" or "METRIC UNITS." Use the [SELECT] key to change option, and then press [ENTER].
3. Choose the desired heart rate input preference by pressing [LEVEL: ^], [3], [2]. The console will then display "HR INPUTS." Press [ENTER]. The console will then display the current hear rate input selection. Press the [SELECT] key to scroll through the other options. Press [ENTER] after the desired option.
4. Change the language by pressing [LEVEL: ^], [3], [4]. The console will display "LANGUAGE." Press [ENTER]. The console will then display the current language. Press the [SELECT] key to scroll through the other options. Press [ENTER] to change the option.
5. Adjust the contrast on the LCD screen by pressing [LEVEL: ^], [3], [5]. The console will display "CONTRAST ADJ." Press [ENTER]. The console will then display the current contrast number. Press the [LEVEL: ^], and [LEVEL: v] keys to increase or decrease the contrast. The changed value will remain on exit.
6. Reset the console to factory defaults by pressing [LEVEL: ^], [3], [9]. The console will display "SET DEFAULTS ." Press [ENTER]. Then console will rest itself and then display "DONE."

Quick Scan Programming

You can quickly access any of the custom menus by pressing [LEVEL: ^], [3], [ENTER]. The console will then display "CUSTOMIZE." Scroll through the following options:

[SELECT]	" MAX TIME "	0
[SELECT]	"CHANGE UNITS"	1
[SELECT]	"HR INPUTS"	2
[SELECT]	"LANGUAGE"	4

4000 PT CONSOLE

[SELECT]	"CONTRAST ADJ"	5
[SELECT]	"MAX SPEED" - N/A -	6
[SELECT]	"CLINICAL MODE" - N/A -	7
[SELECT]	"SET DEFAULTS "	9

Machine Status Codes

[^][4][0]	display machine run time in hours
[^][4][1]	display number of workouts
[^][4][2]	display distance traveled
[^][4][3]	display software rev
[^][4][4]	display machine type
[^][4][5]	-N/A-
[^][4][6]	display machine run time in hours since last cleared (used for maintenance)

1. Display the machine run time by pressing [LEVEL: ^], [4], [0]. The console will display "RUN HOURS XXXXX".
2. Display the number of workouts by pressing [LEVEL: ^], [4], [1]. The console will display "WORKOUTS XXXX."
3. Display the total distance covered up to date by pressing [LEVEL: ^], [4], [2]. The console will then display "DISTANCE XXXX."
4. Display the console software revision number by pressing [LEVEL: ^], [4], [3]. The console will display "CONS 92111-XXX."
5. Display the machine type by pressing [LEVEL: ^], [4], [4]. The console will display "STEPPER (or other machine type)."
6. Display the machine run time since last cleared by pressing [LEVEL: ^], [4], [6]. The console will display "MAINT HOURS XXXX."

Quick Scan Programming

You can quickly access any of the custom menus by pressing [LEVEL: ^], [4], [ENTER]. The console will then display "MACHINE STATUS." Scroll through the following options:

[SELECT]	" RUN HOURS	XXXX"	0
[SELECT]	" WORKOUTS	XXXX"	1
[SELECT]	" DISTANCE	XXXX"	2
[SELECT]	" CONS	90211- XXX "	3
[SELECT]	" STEPPER"		4
[SELECT]	-N/A-		
[SELECT]	" MAINT HOURS	xxxx"	6

Resetting the Maintenance Hour Counter

For ease of maintenance records, the 4000 PT console has a maintenance timer that will clock the number of hours, workouts, and time between last servicing. After each maintenance period reset the counter.

[^][7][1] Reset Service

1. Reset the maintenance hour counter by pressing [LEVEL: ^], [7], [1]. The console will display "RESET SERVICE." Press [ENTER]. The console will display "DONE." Press [CLEAR] to return to the starting screen.

Configuration Code

The 4000 PT® console supports other StairMaster® exercise systems. It is important to verify that the machine configuration code matches the type of machine you have.

[^][8][0] Change Machine

1. Change the machine type by pressing [LEVEL: ^], [8], [0]. The console will display "CHANGE MACHINE." Press [ENTER]. The console will then display the current machine type. Use the [SELECT] key to toggle between options. Press [ENTER] for the desired option.

MAINTENANCE INSTRUCTIONS

HELPFUL HINTS

Read all maintenance instructions thoroughly before beginning work. In some cases, an assistant is required to perform the necessary tasks. All references to the right or left side and to the front or back are made as if you were on the machine ready to exercise.

TOOL LIST

The following tools are needed to perform service and maintenance:

- Torx screwdriver
- combination wrenches (sizes 7/16 - 3/4")
- combination pliers
- volt-ohm meter (multimeter)
- allen wrench set (sizes 5/64 - 1/4")
- shop goggles or other eye protection
- socket set or nut driver set (sizes 1/4 - 3/4" in 1/16" increments)
- phillips screwdriver
- wonder bar (included w/ unit)
- locking pliers
- wire stripper/crimper tool
- external snap ring pliers
- torque wrench

MAINTENANCE RECORDS

For ease of maintenance the 4400/4600 PT/CL console will keep track of hours, number of workouts, time between last servicing, etc. You can quickly access any of the custom menus by pressing [LEVEL: ^], [4], [ENTER]. The console will then display "MACHINE STATUS." Scroll through the following options:

[SELECT]	" RUN HOURS	XXXX"	* 0
[SELECT]	" WORKOUTS	XXXX"	1
[SELECT]	" DISTANCE	XXXX"	2
[SELECT]	" CONS	90211- XXX "	3
[SELECT]	" STEPPER"		4
[SELECT]	-N/A-		
[SELECT]	" MAINT HOURS	xxxx"	6

*The machine may show a few hours of use due to testing at the manufacturing facility.



MAINTENANCE INSTRUCTIONS

INITIAL SERVICE

Upon receiving your machine, use a soft, clean towel to wipe off the dust which may have accumulated during shipping. Your new machine will require minor assembly. Refer to the “Installation Instructions” section for details.

PREVENTIVE MAINTENANCE

Most of these preventive maintenance procedures can be performed after removing the mid-cover. The preventive maintenance schedule is summarized in Table 3. The schedule is based on normal usage in a commercial health club environment; adjust the schedule to meet actual machine usage. Refer to the “Parts Removal and Replacement” section for all disassembly and assembly instructions.

Cleaning

1. DO NOT USE GLASS CLEANERS OR ANY OTHER HOUSEHOLD CLEANERS ON THE CONSOLE. Clean the console daily with a water-dampened cloth and wipe dry after cleaning.
2. Clean the exterior of the machine daily using soap and water or a diluted household cleaner such as Fantastic®.
3. Thoroughly clean the entire machine, including the interior, at least once a week (see Table 3).

Inspecting

1. Inspect the frame for any rust, bubbling, or paint chips during the weekly cleaning. The salt in perspiration can damage the unpainted surfaces.
2. Inspect the Poly-V belt and HTD belts for excessive wear during the quarterly lubrication. Adjust the belt tension if necessary.



MAINTENANCE INSTRUCTIONS

Lubrication

There are nine components that need periodic lubrication: the drive chain, the step chains, the pedal arm return springs, the step chain connection points, the pedal arm bushings, the leveling arm bushings, the spring pulley shafts, the pedal shafts and the leveling arm pins. Remove the bottom cover to get to the components.

1. Place a protective mat on the floor while you lubricate your machine. A rubber floor mat is available from StairMaster® Health & Fitness Products, Inc.
2. Lubricate the drive chain and the step chains weekly. Try to penetrate the entire length of the chains with 30W motor oil.
3. Remove the drive chain and step chains every three months to thoroughly clean and lubricate them. Use a mild degreaser and a stiff brush to remove dirt and corrosion from the chains.
4. Unhook the pedal arm return springs from the spring hanger every week. To protect them from corrosion, wipe the entire length of each pedal arm return spring with a cloth dampened with 30W motor oil before reconnecting it. Replace the spring if it is rusty or otherwise damaged.
5. Remove the double pitch master link from the step chain connection points every three months. Clean the master link and the bushing in the pedal arm. Lubricate the master link and bushing with a thin coat of multi-purpose grease before reassembling.
6. Remove the pedal arms and leveling arms every three months. Clean the pedal arm and leveling arm shafts and bushings with a clean cloth. Protect the shafts from corrosion by wiping them with a cloth dampened with 30W motor oil.

MAINTENANCE INSTRUCTIONS



WARNING

TO REDUCE THE POSSIBILITY OF SLIPPING, BE SURE THE PEDAL AREA IS FREE OF GREASE OR OIL. WIPE ANY EXCESS OIL OFF THE MACHINE SURFACES.

7. Remove the spring pulleys every three months. Clean the spring pulley shafts with a dry cloth. Protect the shafts from corrosion with a thin coat of multi-purpose grease before reassembling.
8. Remove the pedals every three months. Clean the pedal shaft and leveling arm pin with a dry cloth. Protect the pedal shaft and leveling arm pin from corrosion with a light coat of multi-purpose grease before reassembling.

MAINTENANCE INSTRUCTIONS

Table 3: Recommended Preventive Maintenance Schedule

PART	RECOMENDED ACTION	FREQUENCY	CLEANER	LUBRICANT
Console	Wipe Clean	Daily	Water	N/A
Covers	Clean and Inspect	Daily	Diluted household cleaner	N/A
Drive and Step Chains	Lubricate	Monthly or after 300 hours of use	N/A	30W motor oil
	Clean and lubricate	Quarterly or after 900 hours	Mild degreaser	30W motor oil
Step Chain Connection Points	Clean and lubricate	Every 3 months or after 900 hours	Clean, dry rag	Multi-purpose grease
Spring Pulley Shafts	Clean and lubricate	Every 3 months or after 900 hours	Clean, dry rag	Multi-purpose grease
Pedal Shafts and Leveling Arm Pins	Clean and lubricate	Every 3 months or after 900 hours	Clean, dry rag	Multi-purpose grease
Pedal Arm Springs	Inspect and wipe down	Each week or 70 hours	N/A	Clean, oil-dampened rag
Pedal Arm Shafts	Clean and lubricate	Every 3 months or after 900 hours	Clean, dry rag	30W motor oil
Battery	Check Voltage	Every 3 months or after 900 hours	N/A	N/A
Belts	Inspect & Adjust Tension	Every 3 months or after 900 hours	N/A	N/A

****Note: Use of lubricants other than those specified will result in diminished performance and a shorter life span for that part.***

GENERAL TROUBLESHOOTING GUIDELINES

This troubleshooting section is organized into three basic problem sections: electrical troubleshooting, console diagnostic tests, and mechanical troubleshooting. Once you have identified the problem section, perform all the tests in the same order as written. To order a replacement part or for help with troubleshooting, contact our Customer Service Department. Refer to the Appendix for the appropriate phone number.

ELECTRICAL TROUBLESHOOTING

The 4000 PT[®] electrical system has four major components: the alternator, the power supply, the power cables, and the console. The console and power supply are not serviceable by the owner. If any of these parts are inoperable, they must be replaced. Opening the console or the power supply will void the warranty.

1. Use a voltmeter set on VAC to verify that the AC wall outlet has 100 to 120 VAC (or 220 to 240 VAC, if applicable). If you do not have a voltmeter plug in an alternate AC-powered device (e.g., a lamp). If the device does not work when plugged into the electrical outlet, consult an electrician for further assistance and then retest the electrical outlet.
2. Plug the power supply into the wall outlet. The green Light Emitting Diode (LED) on the power supply should be on. If the LED does not light up, replace the power supply.
3. Disconnect the DC cable from the left side panel. Set the voltmeter to VDC and test for 12 to 19 VDC in pins #1 (+) and #2 (-). Replace the power supply if the voltage reading is outside the specified range.
4. Remove the bottom cover and connect the DC cable to the power connector on the left side of the frame. Locate the black and white wires on the backside of the power connector.

ELECTRICAL TROUBLESHOOTING

5. Follow the white power connector wire to the where it plugs into the main **white cable**, and disconnect it from the main **white cable** white wire.
6. Set your voltmeter to VDC. Connect the positive lead of your voltmeter to the white wire from the power connector and touch the gray casing of the alternator with the negative lead of your voltmeter.
7. DC voltage measured should be 12 to 19 VDC. Replace the power connector if the voltage is not the same value as in step 3. Connect the two white wires.
8. Remove the console knobs from the back of the console, lift the console up, and disconnect the 20-pin main **white cable** from the console.
9. Test for 12 to 19 VDC in pins #1 (-) and #10 (+) in the main **white cable** connector. Replace the main **white cable** if the voltage reading is not the same as in step 7.

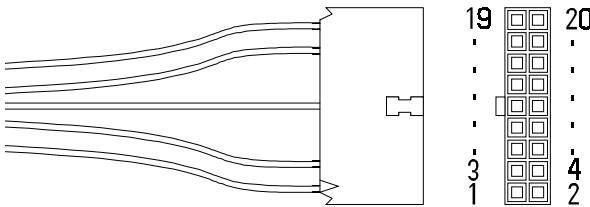

10. If all voltage readings have been within the specified range and the console will not power up, the console should be replaced.

Alternator Test

11. Check for loose wiring connections on the alternator, diode, and load resistor.
12. Perform the Positive Output to Field test on the alternator:
 - Disconnect the power cord from the electrical outlet.
 - Remove the black wire from the B+ terminal on the alternator.
 - Remove the brown wire from the field terminal on the alternator.



ELECTRICAL TROUBLESHOOTING

- Place a short wire with alligator clips on the B+ terminal and the field (FLD) terminal of the alternator.
- Step on the machine for approximately 10 to 15 seconds.
- If full resistance is achieved during this time, your alternator has correct current flow. If no resistance is achieved, replace the alternator.

Diode Test

13. Remove the brown wire and diode from the field terminal of the alternator and set your voltmeter to the Ohms setting.
14. Place one lead from the voltmeter on each end of the diode, and then reverse the leads. A diode that is good will show a high reading in one direction and a low reading when the leads are reversed. Replace the diode if the readings recorded are both high or both low.

Resistor Test

15. Remove one wire from the load resistor (see Final Assembly Figure) and place one lead from the voltmeter on each of the threaded posts on the load resistor. Replace the load resistor if the voltmeter does not read 0.5 Ohms ($\pm 10\%$).
16. If the problem still exists, contact the Customer Service Department at 800-331-3578.

CONSOLE DIAGNOSTIC TESTS

The following tests are performed while the console is in the "SELECT WORKOUT" mode. If the console fails any test, the console should be replaced or exchanged. To return to the "SELECT WORKOUT" mode, press either [CLEAR] or [STOP] while in the DIAGNOSTIC mode. Please note that there may be additional verbiage on the display other than is listed in this manual. The 4000 PT® console is used on other StairMaster® equipment.

DIAGNOSTIC CODES

- [^][6][0] Test display
- [^][6][1] Test keyboard
- [^][6][2] Test serial port
- [^][6][3] Test alternator
- [^][6][4] **-N/A-**
- [^][6][5] **-N/A-**
- [^][6][6] Test Tach
- [^][6][7] - [6][9] **-N/A-**

Display Test

During the display test, the console screen alternates between all LCD segments turned on and the sample program profile screen at a 2-second rate.

1. Press [LEVEL: ^], [6], [0], [ENTER]. The console will display "DISPLAY TEST".
2. All LCD segments will turn on for 2 seconds, and then a sample program profile will be displayed for 2 seconds. Press [CLEAR] to end the test.

Keypad Test

Perform this test if you are having trouble entering data into the console. During the test, pressing any key displays that key name on the message line. Press [CLEAR] to exit.

1. Press [LEVEL: ^], [6], [1], to start the test.

CONSOLE DIAGNOSTIC TESTS

2. Firmly press each button except [CLEAR]. The name of the key will be shown in the display window. Press [CLEAR] to end the test.

Serial Port Test

This test verifies that the RS 232 port used for linking to external C.S.A.F.E. systems (commercial entertainment systems) is working. You must have the loop-back **cable** assembly (PN 040051-001) to perform this test.

1. Insert the loop-back **cable** assembly into the RS 232 port on the back of the console.
2. Press [LEVEL: ^], [6], [2]. The console will display "SERIAL TESTS." Press [ENTER] to access the C.S.A.F.E. test.
3. Press [ENTER] a second time. The console will run a diagnostic test and then display either "PASS" or "FAIL." Replace the console if it fails this test.

Alternator Test

Use this test to verify the alternator field routines of the console. You will need to briefly exercise on the machine for this test.

1. Press [LEVEL: ^], [6], [3], to start the test.
2. For "Field on" press [LEVEL: ^]. Step on the machine for approximately 10 to 15 seconds. If full resistance is achieved during this time, your console has correct current flow. If no resistance is achieved, either the console or the alternator is bad. See the electrical troubleshooting portion of this manual to isolate and test the alternator. Replace the console if the alternator is good.
3. For "Field off" press [LEVEL: V]. Step on the machine for approximately 10 to 15 seconds. You should not get resistance with the field turned off. Press [CLEAR] to end the test.

CONSOLE DIAGNOSTIC TESTS

Tach Test

If you do not have resistance, perform the tach test. The tach test will tell you the tach signal, in revolutions per minute (RPMs), picked up by the console.

1. Press [LEVEL: ^], [6], [6], [ENTER]. The console will display "TAR TACH ACT." The target tach speed of 2,000 RPMs will be shown in the upper left corner of the display window. The actual tach picked up by the console will be shown in the upper right corner of the display window.
2. Start stepping on the pedals. The number in the right hand corner of the console should increase to 2,000 RPMs (+/- 200). If the tach signal picked up by the console is less then 1,900 RPMs then there is a problem in the AC tach circuit - either with the console software, alternator (check the AC tach wire, the field wire, the diode, and the terminal posts), or the main **cable**.

Error Reporting

The console will display various error messages in the display window. The total amount of errors will be displayed in the upper right numeric window. Note that only the highest priority reported error will be displayed. Errors are handled in two ways. One as a non-fatal "WARNING" which will display the text message but continue system operation until the user presses the [CLEAR] key. The second way is as a fatal "ERROR" which will stop the exercise and return the system to an idle intensity state. The console will display the error text and not let the user restart the programs unless power has been turned off and then back on.

The following microprocessor errors require a console replacement; ALU ERROR, TIMER ERROR, and STATIC RAM ERROR.

Resetting the power may clear the following microprocessor errors; EEPROM ERROR, and PROGRAM ERROR. If resetting the power doesn't work, the console may need to be replaced.

CONSOLE DIAGNOSTIC TESTS

The Telemetry (Polar®) Heart Rate Test

The telemetry heart rate system is made up of the console, the heart rate receiver, and the chest strap (available separately). You can test each component by performing the following steps:

1. You will need to put a chest strap on in order to test the telemetry heart rate. Before you put on the chest strap, wet the two contact patches. Secure the chest strap as high under your pectoral muscles (chest) as is comfortable. The chest strap should fit snugly, comfortably, and allow normal breathing.
2. A flashing ♥ should be displayed on the console. Your heart rate, in beats per minute, will show next to the heart icon. If the heart icon does not show, or if your heart rate is not displayed on the console then you have a problem with either the console, chest strap, or heart rate receiver.
3. Verify that the console software has been set up to receive telemetry (see the heart rate monitoring section of this manual). Note that holding the contact heart rate sensors (if enabled) can inhibit the telemetry heart rate input from working.
4. Test your chest strap with a machine that you know is working, or with a heart rate watch that you know is working.
5. If possible, replace or exchange your console with a machine that you know is working and retest the machine.
6. Excess false heart rate detection: the telemetry receiver located in the console is susceptible to mechanical vibration as well as external electrical interference. Hitting the console or the frame may momentarily cause errant heart beat detection - this is normal. If excessive false heart beats appear only during workouts, check that the console **cable** is not curled up behind the console. Pull as much of the **cable** down and away from the console as possible. False heart beats while the machine is idle are most likely due to external interference. Try plugging the machine into a different outlet, or moving it to a new location.

MECHANICAL TROUBLESHOOTING

If you hear a grinding or clicking noise, experience excessive vibration during exercise, or if the pedals are not functioning properly, you probably have a problem in the drive train. Attempt to isolate the problem area by performing the following tests in precisely the order listed below.

1. Unplug the machine and remove the bottom side covers.



WARNING

TO REDUCE THE RISK OF INJURY, DO NOT OPERATE THE MACHINE WHILE THE COVERS ARE REMOVED. DO NOT DEPRESS OR RAISE THE PEDALS WHILE ANYONE'S HANDS ARE INSIDE THE MACHINE.

2. Noise can be generated by a Poly-V belt that is either too tight or too loose. Check the condition and the tension of the belt. Replace a worn belts. Adjust the belt tension according to the instructions in the "Parts Removal and Replacement" section.
3. Remove the Poly-V belt and move the pedal arms. If the noise no longer exists, check the condition of the alternator. If the noise is still present, go to step #4. Do not reinstall the Poly-V belt if performing step #4.
 - Disconnect the DC power **cable**. Spin the alternator pulley with your fingers. It should spin freely and remain spinning for at least two revolutions. If it does not, the alternator should be replaced.
 - If the alternator does spin freely, check the alternator for noise, roughness, or the presence of an excessive amount of black powder inside the alternator or near the outside of the case. If any of these conditions exist, the brushes might be bad. Replacement brushes are available as well as replacement alternators.
4. Tighten the transmission pulley set screw onto the flat side of the transmission output shaft. Tighten the transmission drive sprocket set screw to the keyway in the transmission input shaft.

MECHANICAL TROUBLESHOOTING

5. Remove the drive and step chains. Check the condition of the chains by flexing each link up and down. Each link should move freely. Replace the chain if any stiff or inflexible links are found or if the chain is rusty, corroded, or otherwise damaged. Do not reinstall the chains.
6. Spin the transmission drive sprocket input 1 complete revolution. The transmission pulley output should turn 19 revolutions. Replace the transmission if any clicking or grinding noises are heard during rotation or the drive ratio is not 19 to 1.
7. Check the pedal arm and leveling arm shafts by removing both the right and left pedal and leveling arms. Inspect the shafts and the bushings for signs of wear and corrosion. Replace the bushing(s) if worn.
8. Remove the pedals. Clean any corrosion off the pedal shaft with an oil-dampened rag. Apply a thin coat of multi-purpose grease to the shaft. If the noise persists, go to step 10. Check the step chain connection point. Clean and grease the master link and bushing. Replace damaged parts.
9. Check the drive hub assembly.
 - Check the condition of the drive sprocket teeth. The teeth should not be unevenly worn. Replace the worn sprocket(s).
 - The drive sprockets work independently of one another. Each sprocket should turn freely in one direction and lock when turned in the other direction. Replace an inoperable drive sprocket.
 - Remove the drive shaft. Inspect the bearings in the drive hub. Replace the drive hub assembly if the shaft does not spin freely or if there is excessive radial play at the shaft. Be careful not to get dirt into the hub.
 - Inspect the ends of the drive shaft (at the sprocket attachment points) for signs of wear or scoring. Replace the shaft if it is excessively worn.

PARTS REMOVAL AND REPLACEMENT

ALTERNATOR

1. Remove the side panels.
2. Mark the location of each wire attached to the alternator then remove the wires from the alternator (See figure 7).
3. Remove the alternator adjusting bolt on the slotted brace.
4. Remove the Poly-V belt and inspect the belt for wear. Replace the belt if it is cracked, cut, or is otherwise damaged.
5. Support the alternator while removing the nyloc nut and the alternator mounting bolt from the frame.
6. Remove the alternator from the frame.
7. Reverse the removal procedures to install the new alternator.
8. Verify that the alternator is wired correctly (See figure 7) and that the Poly-V belt deflection is set to allow 1/4" (0.6 cm) of belt deflection before applying power to the machine (see Figure 8).

ALTERNATOR BELT



WARNING

THE BELTS MUST BE PROPERLY TENSIONED. A BELT THAT IS TOO TIGHT WILL CAUSE SLOW AND SLUGGISH OPERATION. A BELT THAT IS TOO LOOSE WILL CAUSE EXCESSIVE NOISE AND BELT WEAR.

1. Remove the side covers.
2. Loosen the alternator adjustment screw that mounts the alternator brace to the alternator, and the pivot adjusting bolt that mounts the alternator to the frame.



PARTS REMOVAL AND REPLACEMENT

3. Pivot the alternator down and remove the Poly-V belt.
4. Make sure the Poly-V belt is centered on the pulleys during installation.
5. Pivot the alternator up or down as necessary to allow 1/4" (0.6 cm) of belt deflection with fingertip pressure at the midpoint between the two pulleys (See figure 8).
6. Tighten the alternator adjustment bolt and the pivot adjustment bolt. Verify 1/4" (0.6 cm) deflection in the belt.
7. Reinstall the covers.

CONSOLE

1. Remove the four mounting knobs from the back of the console.
2. Disconnect the main cable from the back of the console.
3. Remove the console.
4. Reverse the steps to reinstall the console.

COVERS

Each side cover is secured to the mainframe of the machine with three quarter turn fasteners: two fasteners in the top of the side panel and one in the lower portion of the panel near the floor.

1. Disconnect the power supply from the right side panel.
2. Use a phillips screwdriver to remove the lower fastener by turning it counter clockwise one quarter of a full turn.
3. The fastener will remain attached to the panel when the screw driver is removed.

PARTS REMOVAL AND REPLACEMENT

4. Support the panel while removing the two top fasteners the same way the single lower fastener was removed.



WARNING

TO REDUCE THE RISK OF INJURY, DO NOT OPERATE THE MACHINE WHILE THE COVERS ARE REMOVED. DO NOT DEPRESS OR RAISE THE PEDALS WHILE ANYONE'S HANDS ARE INSIDE THE MACHINE.

5. Carefully lower the side panel to the floor and unplug the internal power connector (right side only).
6. Once all three fasteners have been removed and the internal power connector has been disconnected (right side only) you may remove the panel from the machine

DRIVE CHAIN

1. Remove the bottom cover.
2. Remove the master link from the drive chain.
3. Remove the drive chain from the sprockets.
4. Reinstall the drive chain, ensuring the master link is properly installed.
5. Check the drive chain tension. There should be a total of 1" to 1-1/2" (2.5 to 4.0 cm) of play, up and down, at the slackest point in the chain. If the drive chain tension needs adjustment, refer to the "Drive Hub Assembly" section.



WARNING

IF THE DRIVE CHAIN IS TOO TIGHT, THE DRIVE TRAIN WILL WEAR EXCESSIVELY, SHORTENING THE LIFE OF THE DRIVE HUB. IF THE CHAIN IS TOO LOOSE, THE MACHINE WILL BE NOISY AND WILL OPERATE AT LESS THAN PEAK EFFICIENCY.

PARTS REMOVAL AND REPLACEMENT

6. Lubricate the chain with 30W motor oil and wipe off the excess.
7. Reinstall the covers.

DRIVE HUB ASSEMBLY

1. Remove the side covers.
2. Remove the step chain retainers.
3. Support the pedal arm. Unhook the pedal arm return spring from the spring hanger. Lift the step chain up and off the clutch sprocket and lower the pedal arm to the floor. Repeat on the other side.
4. Remove the snap ring from the left end of the drive shaft (see Figure 9).



WARNING

TO REDUCE THE RISK OF EYE INJURY, WEAR EYE PROTECTION WHEN REMOVING SNAP RINGS.

5. Remove the drive chain.
6. Remove the sprocket and the other small parts from the left side of the hub assembly (see Figure 9).
7. Slide the drive shaft to the right, out of the hub assembly. If you remove the right-hand clutch sprocket from the drive shaft, do not confuse it with the left-hand clutch sprocket.
8. Loosen and remove the two remaining bolts and nuts that hold the hub assembly to the frame. Remove the hub assembly.
9. Inspect the drive shaft, bushings, thrust washers, and clutch sprockets for excessive wear or pitting. Replace any worn components.



PARTS REMOVAL AND REPLACEMENT

10. To reinstall the hub assembly, carefully reverse the disassembly procedures. Be sure that the right- and left-hand clutch sprockets are positioned correctly; the wide shoulder of the sprocket should be facing away from the hub on both sides.
11. Chain Tension. The drive shaft is mounted in an eccentric hub (see Figure 10). Rotate the hub so the marked hole is in the 12 o'clock position, lining up four holes in the hub with the four holes in the frame. Use this hub position when reinstalling the drive chain since the distance between the drive and transmission shafts is at a minimum. The hub is in the proper position when the drive chain has a total of 1" to 1-1/2" (2.5 to 4.0 cm) of play at the slackest point. As the drive chain stretches with use, increase the chain tension (and the distance between the two shafts) by rotating the hub counterclockwise. The distance between the two shafts is greatest when the marked hole in the hub is at the 8 o'clock position.
12. Reinstall the covers.

HANDGRIPS

1. Order the field installable handgrip kit from your local representative and follow the instructions included with the kit.

HANDLEBAR

1. Unscrew the main **cable** connector from the receptacle on the back of the console.
2. Unscrew the four console mounting screws and remove the console from the machine.
3. Lift the rear tube of the frame. Tip the machine forward so it is resting on the front portion of the frame.
4. Remove the two bolts that hold the handrail to the frame tube.

PARTS REMOVAL AND REPLACEMENT

5. Stand the machine upright and remove the four bolts that secure the handrail to the mainframe near the console mount.
6. Remove the handrail from the frame.
7. Reverse the removal procedures to reinstall the handrail.

LEVELING ARM

1. Remove the pedal.
2. Remove the side covers.
3. Remove the snap ring that secures the leveling arm to the leveling arm shaft.



WARNING

TO REDUCE THE RISK OF EYE INJURY, WEAR EYE PROTECTION WHEN REMOVING SNAP RINGS.

4. Slide or gently tap the leveling arm off the shaft.
5. Clean the shaft and the pin with a cloth dampened with 30W motor oil before reassembly. DO NOT SAND THE SHAFT.
6. Reverse the removal procedures to reinstall the leveling arm.

PEDAL

1. Remove the snap ring and flat washer from the leveling arm pin and the pedal shaft.



WARNING

TO REDUCE THE RISK OF EYE INJURY, WEAR EYE PROTECTION WHEN REMOVING SNAP RINGS.

PARTS REMOVAL AND REPLACEMENT

2. Slide the pedal off the pedal shaft and leveling arm pin.
3. Clean the pedal shaft and leveling arm pin with a dry cloth. Lubricate the pedal shaft and the pin with a thin coat of multipurpose grease.
4. Reverse the removal procedures to reinstall the pedal.

PEDAL ARM

1. Remove the pedal.
2. Remove the side covers.
3. Remove the step chain retainers.
4. Support the pedal arm. Unhook the pedal arm return spring from the spring hanger. Lift the step chain up and off the clutch sprocket and lower the pedal arm to the floor.
5. Remove the master link from the step chain connection point (see Figure 11).
6. Remove the snap ring from the pedal arm shaft.



WARNING

TO REDUCE THE RISK OF EYE INJURY, WEAR EYE PROTECTION WHEN REMOVING SNAP RINGS.

7. Slide or gently tap the pedal arm off the mounting shaft.
8. Clean the pedal arm shaft with a cloth dampened with 30W motor oil before reassembly. DO NOT SAND THE SHAFT.
9. Reverse the removal procedures to reinstall the pedal arm.

PARTS REMOVAL AND REPLACEMENT

PEDAL ARM RETURN SPRING

1. Remove the bottom cover.
2. Unhook the pedal arm return spring from the spring hanger.
3. Detach the spring from the step chain by removing the master link (see Figure 11). The spring-chain connector is in good condition if it has an hour glass shape. Replace a worn spring-chain connector.
4. Check to ensure that the spring pulley turns freely and is not worn excessively. Refer to the "Spring Pulley" section if you have to replace the pulley.
5. To reinstall the spring, connect it to the end of the step chain using the master link.
6. Route the spring under the spring pulley.
7. Hook the end of the pedal arm return spring onto the spring hanger.



WARNING

DO NOT TWIST THE SPRING DURING INSTALLATION. IT WILL WEAR EXCESSIVELY AND REDUCE THE LIFE OF THE SPRING.

8. Reinstall the covers.

SPRING PULLEY

1. Remove the bottom cover.
2. Unhook the pedal arm return spring from the spring hanger.
3. Remove the snap ring from the pulley shaft.

PARTS REMOVAL AND REPLACEMENT



WARNING

TO REDUCE THE RISK OF EYE INJURY, WEAR EYE PROTECTION WHEN REMOVING SNAP RINGS.

4. Slide the pulley and washer off the shaft.
5. Before reinstalling the pulley, clean the pulley shaft thoroughly with a clean, dry cloth. Apply a thin coat of multipurpose grease to the pulley shaft.
6. Slide the pulley and washer onto the shaft. Install the snap ring.
7. Route the spring under the spring pulley.
8. Hook the end of the spring over the spring hanger.



WARNING

DO NOT TWIST THE SPRING DURING INSTALLATION. IT WILL WEAR EXCESSIVELY AND REDUCE THE LIFE OF THE SPRING.

9. Reinstall the cover.

STEP CHAIN

1. Remove the side covers.
2. Remove the step chain retainers.
3. Support the pedal arm. Unhook the pedal arm return spring from the spring hanger. Lift the step chain up and off the clutch sprocket and lower the pedal arm to the floor.
4. Remove the double-pitch master link and bearing sleeve assembly from the step chain connection point on the pedal arm (see Figure 9).



PARTS REMOVAL AND REPLACEMENT

5. Remove the master link from the spring-chain connection.
6. Reverse the procedures to reinstall the step chain. Lubricate the step chain before reinstalling the covers.

STEP CHAIN RETAINER

1. Remove the side covers.
2. Loosen and remove the two step chain retainer bolts. These bolts are also the top two mounting bolts for the drive hub assembly.
3. Reverse the removal procedures to install. Make sure there is adequate clearance between the step chain and the retainer.

TRANSMISSION

1. Remove the side covers
2. Remove the Poly-V belt.
3. Remove the drive chain.
4. Remove the two screws located on the transmission bracket.
5. Support the transmission while removing the four mounting screws from the back side of the transmission.
6. Installation is the reverse of removal.

GROUNDING INSTRUCTIONS

The machine must be grounded if you are using the external power supply or the battery charger. Grounding provides the path of least resistance for the electric current, thereby reducing the risk of electric shock. The power supply or battery charger must be plugged into an appropriate outlet that is properly installed and grounded in accordance with all local codes and ordinances.



DANGER

IMPROPER CONNECTION OF THE EQUIPMENT-GROUNDING CONNECTOR CAN RESULT IN THE RISK OF ELECTRIC SHOCK. CHECK WITH A QUALIFIED ELECTRICIAN OR SERVICE PERSON IF YOU ARE IN DOUBT AS TO WHETHER THE MACHINE IS PROPERLY GROUNDED. DO NOT MODIFY THE PLUG PROVIDED WITH THIS MACHINE. IF IT WILL NOT FIT THE AVAILABLE OUTLET, HAVE A PROPER OUTLET INSTALLED BY A QUALIFIED ELECTRICIAN.

The grounding plug on the power supply and the battery charger is shown in sketch A below*. A temporary adapter, shown in sketches B and C, may be used to connect the plug to a two-pole receptacle if a properly grounded outlet is not available. The adapter should be used only until a properly grounded outlet (sketch A) can be installed by a qualified electrician. The tab extending from the adapter must be connected to a permanent ground such as the metal screw on the outlet cover.

* This may vary for International power supplies.

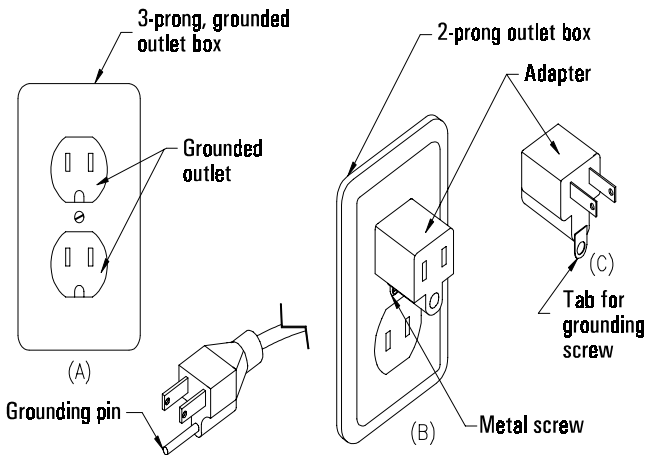

Figure 5: Grounding System

FCC COMPLIANCE

This equipment has been tested and found to comply with the limits for a Class B digital device, pursuant to Part 15 of the FCC rules. These limits are designed to provide reasonable protection against harmful interference in a residential installation. This equipment generates, uses and can radiate radio frequency energy and, if not installed and used in accordance with the instructions, may cause harmful interference to radio communications. However, there is no guarantee that interference will not occur in a particular installation. If this equipment does cause harmful interference to radio or television reception, which can be determined by turning the equipment off and on, the user is encouraged to try to correct the interference by one or more of the following measures:

- Reorient or relocate the receiving antenna.
- Increase the separation between the equipment and receiver.
- Connect the equipment into an outlet on a circuit different from that to which the receiver is connected.
- Consult the dealer or an experienced radio/TV technician for help.



WARNING

CHANGES OR MODIFICATIONS TO EQUIPMENT NOT EXPRESSLY APPROVED BY STAIRMASTER® HEALTH & FITNESS PRODUCTS, INC. COULD VOID THE USER'S AUTHORITY TO OPERATE THIS EQUIPMENT.

CANADIAN DOC CLASS B COMPLIANCE

This digital apparatus does not exceed the Class B limits for radio emissions from digital apparatus set out in the radio interference regulations of the Canadian Department of Communications.

La présent appareil numérique ne dépasse pas les limites établies pour les bruits radioélectriques applicables aux appareils numériques de la Class B prescrites dans les règlement sur le brouillage radioélectrique édicté par le Ministère des Communications du Canada.



IMPORTANT PHONE NUMBERS

If you need assistance, please have both the serial number of your machine and the date of purchase available when you contact the appropriate StairMaster® Health & Fitness Products, Inc. office listed below.

OFFICES IN THE UNITED STATES

CORPORATE HEADQUARTERS

12421 Willows Road NE, Suite 100
Kirkland, WA 98034
(800) 635-2936 or (425) 823-1825
FAX: (425) 823-9490
www.stairmaster.com

CUSTOMER SERVICE

12421 Willows Road NE, Suite 100
Kirkland, WA 98034
(800) 331-3578
FAX: (425) 814-0601
E-mail: customerservice@
stairmaster.com

INTERNATIONAL OFFICES AND DISTRIBUTORS

For technical assistance and a list of distributors in your area, please call or fax one of the following numbers.

INTERNATIONAL DIVISION

(425) 823-1825
FAX: (425) 820-7505
E-Mail: intlservice@stairmaster.com

ASIA PACIFIC HEADQUARTERS

Telephone/Fax: +81-45-590-5686
E-mail: stairintl@aol.com

EUROPE: HEADQUARTERS

+41-91-827-3801
FAX: +41-91-827-8902
E-Mail: stairmasterch@swissonline.ch

GERMANY: HEADQUARTERS

+49-2204/610-27
FAX: +49-2204/628-90
E-Mail: stairmaster.de@t-online.de

U.K.: HEADQUARTERS

+44-1908/267-345
FAX: 44-1908/267-346
E-mail: stairmasteruk@msn.com

Figure 6: Final Assembly, Left Side

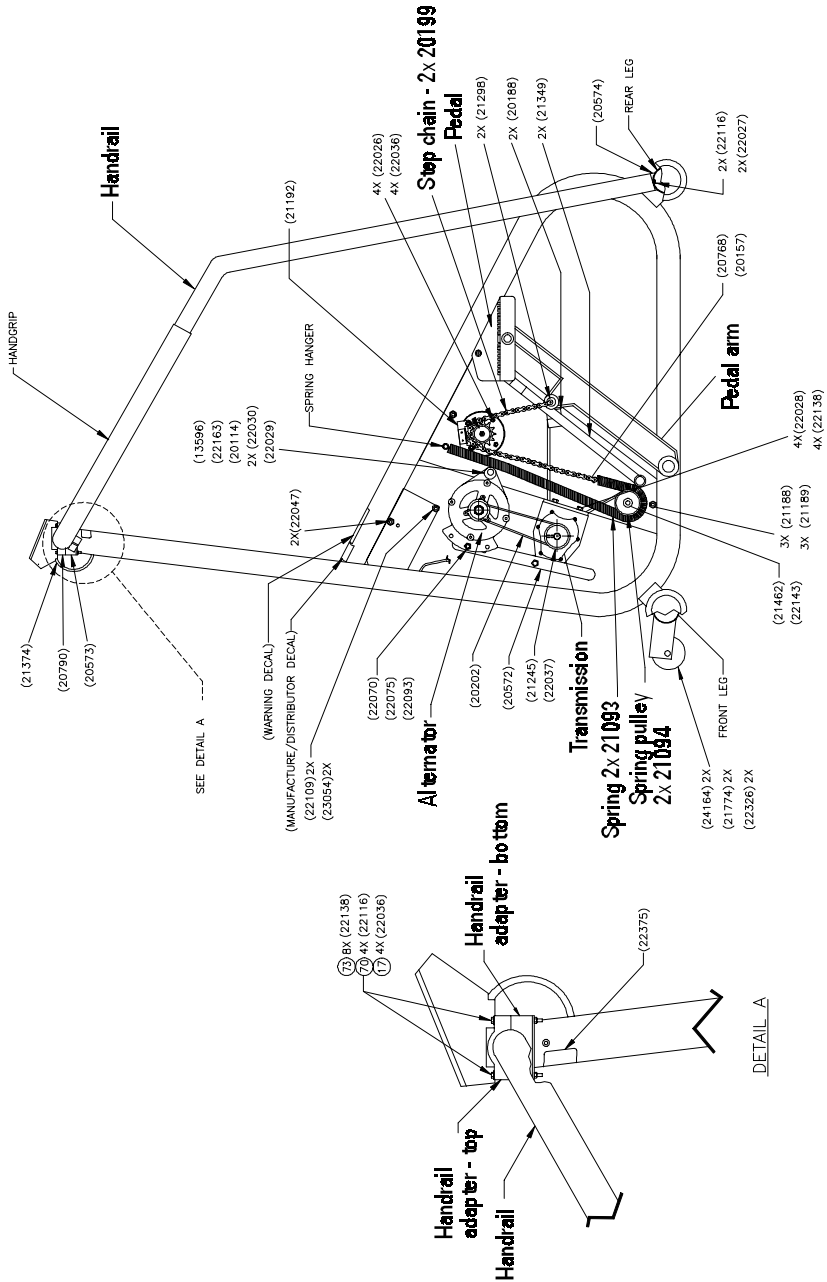

FIGURES

Figure 7: Final Assembly, Right Side

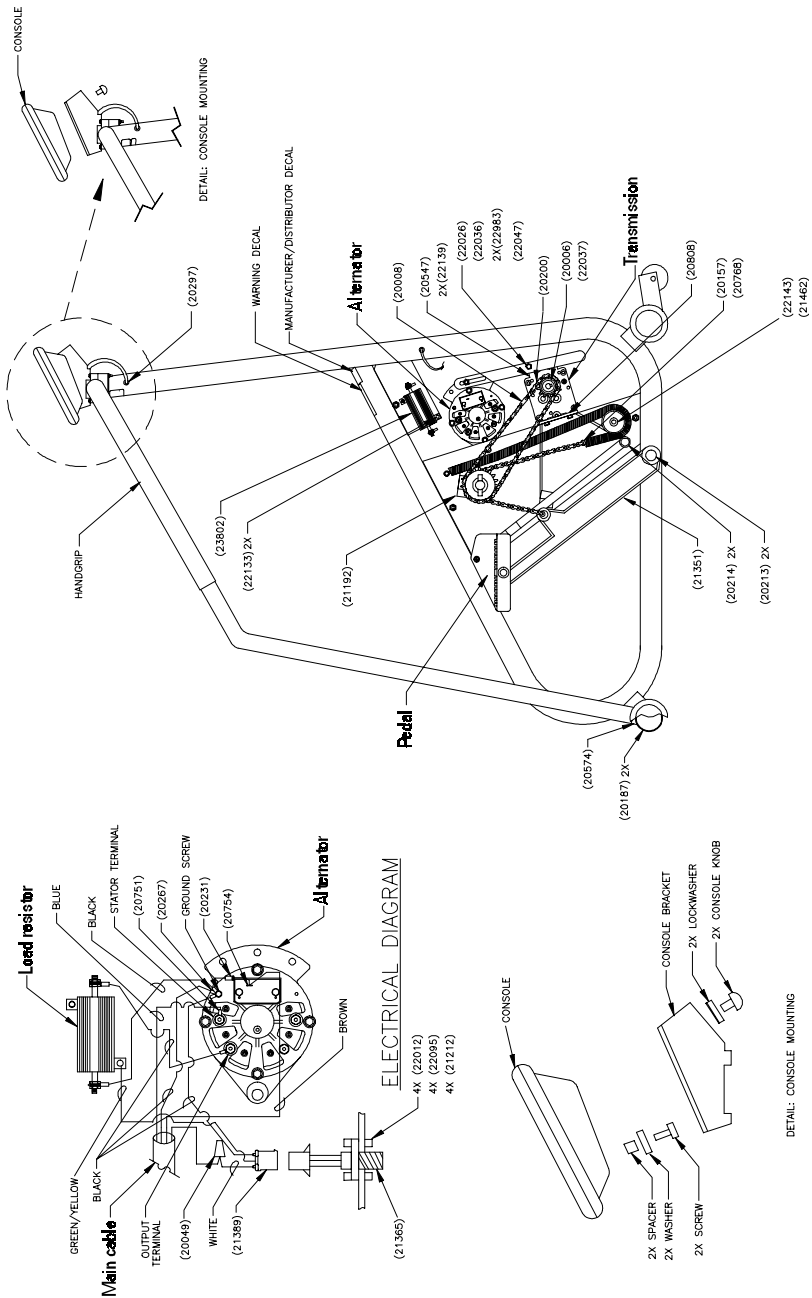
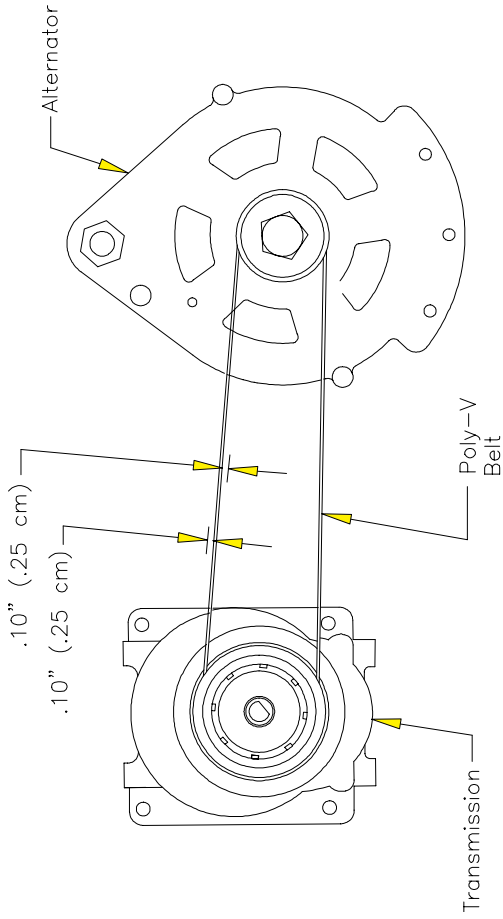

Figure 8: Belt Tension



FIGURES

Figure 9: Drive Hub Assembly

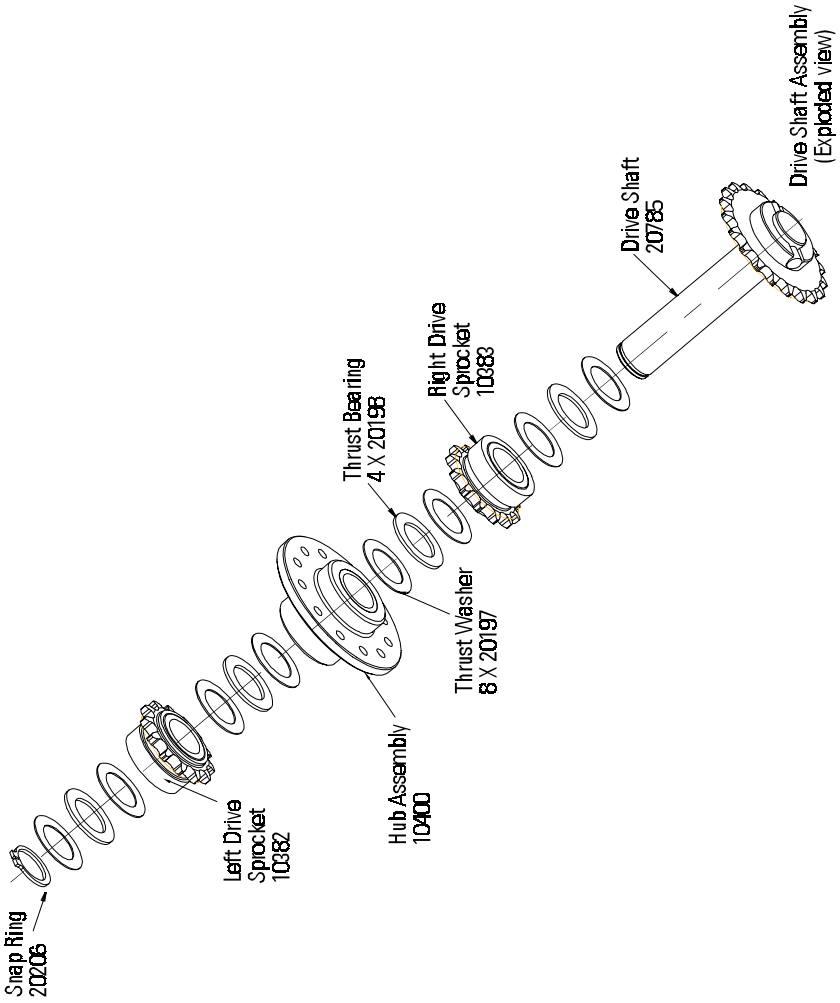
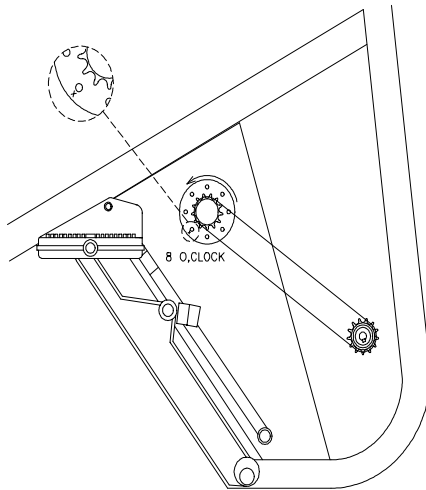
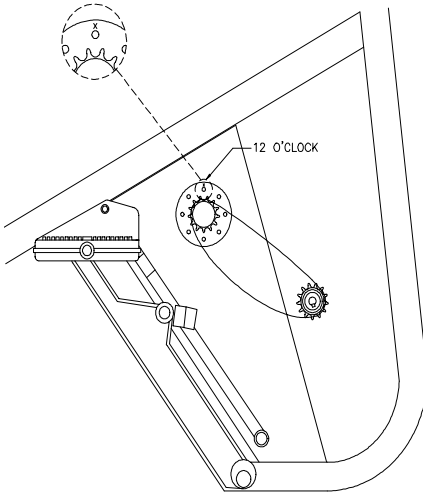

Figure 10: Drive Chain Tensioning



FIGURES

Figure 11: Left Pedal Arm Assembly

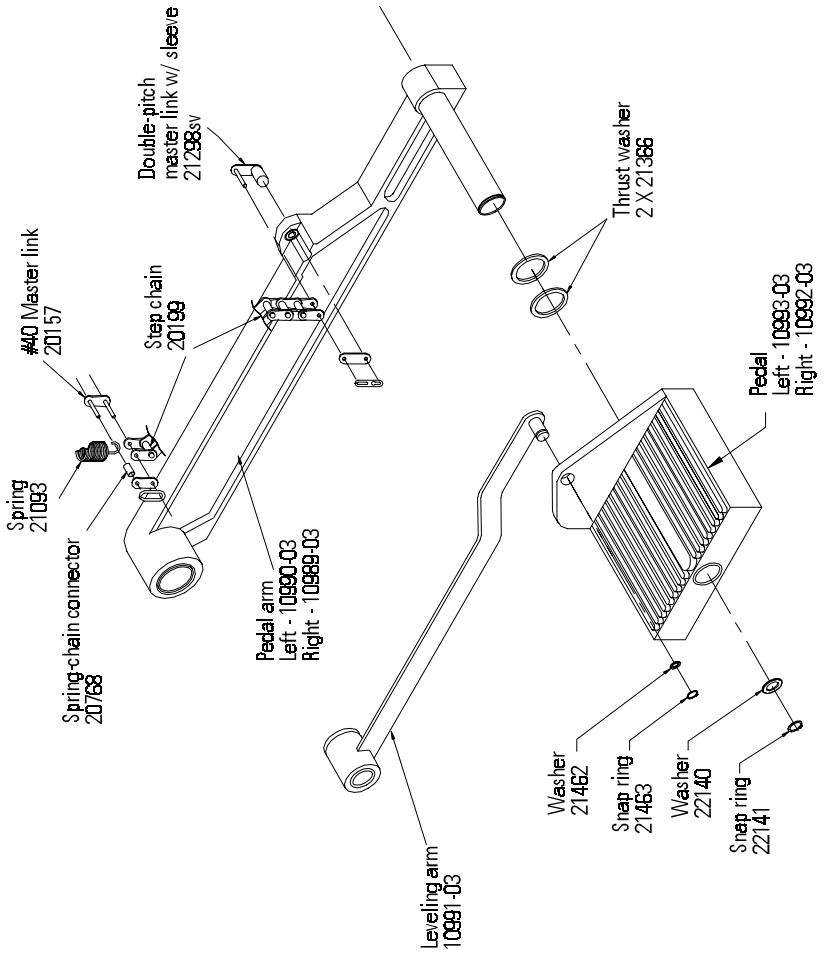

Figure 12: Transmission

